

DC HIGH VOLTAGE EV RELAY

EVD150



EVD150

PERFORMANCE

ITEM	PARAMETER	
Contact Arrangement	SPST-NO	
Auxiliary Contact	SPST-NO(Optional)	
	MIN Load: 8Vdc 100mA ; Contact Resistance: ≤100mΩ	
Voltage Rating	12-200Vdc	12-750Vdc 12-1000Vdc 12-1500Vdc
Current Rating	1-150A	
Current Endurance	150A Cont. ; 180A 10min. ; 250A 180sec. ; 300A 50sec.	
Break Current, Max (only 1 time)	1000A 320Vdc	
Contact Resistance (Initial)	≤1mΩ (at 150A)	
Operate Time (at 20°C)	30ms Max.	
Bounce Time (at 20°C)	5ms Max.	
Release Time (at 20°C)	10ms Max.	
Mechanical Life (0.5s:0.5s)	2×10 ⁵ Cycles	
Electrical Life	See graph	
Current-carrying capacity curve	See graph	
Insulation resistance	Initial: 100MΩ 1000Vdc	
	After test: 50MΩ 1000Vdc	
Impulse withstand voltage (initial)	Main contact 1mA/1min.(sea level)	AC 3500Vrms
	Main contact & coil 1mA/1min.(sea level)	AC 2500Vrms AC 3500Vrms
Mechanical performance	Shock	20G peak,11ms 1/2 Sine wave (coil energized)
	Vibration	20G peak,80-2000Hz,Sine wave (coil energized)
	Strength	50G acceleration, half sine wave impulse 6ms, 50 times per axis.
Operating & Storage Condition	Ambient Temperature	-40~+85°C
	Humidity	5~95% RH.
Altitude	≤4000m	
Weight	approx. 160g	
Certification	UL、CE、CCC	

COIL DATA

Coil Type	Nominal voltage (at 20°C)	Pick-up voltage (at 20°C)	Drop-out voltage (at 20°C)	Coil resistance (at 20°C)	Holding power (at 20°C)	Coil polarity
Single-coil	12Vdc	≤9.6Vdc	≥1Vdc	26Ω×(1±7%)	approx. 5.5W	non-polarized
	24Vdc	≤19.2Vdc	≥2Vdc	96Ω×(1±7%)	approx. 6.0W	non-polarized
	48Vdc	≤38.4Vdc	≥4Vdc	392Ω×(1±7%)	approx. 5.9W	non-polarized

DC HIGH VOLTAGE EV RELAY

EVD150



PART CODE



DIMENSIONS

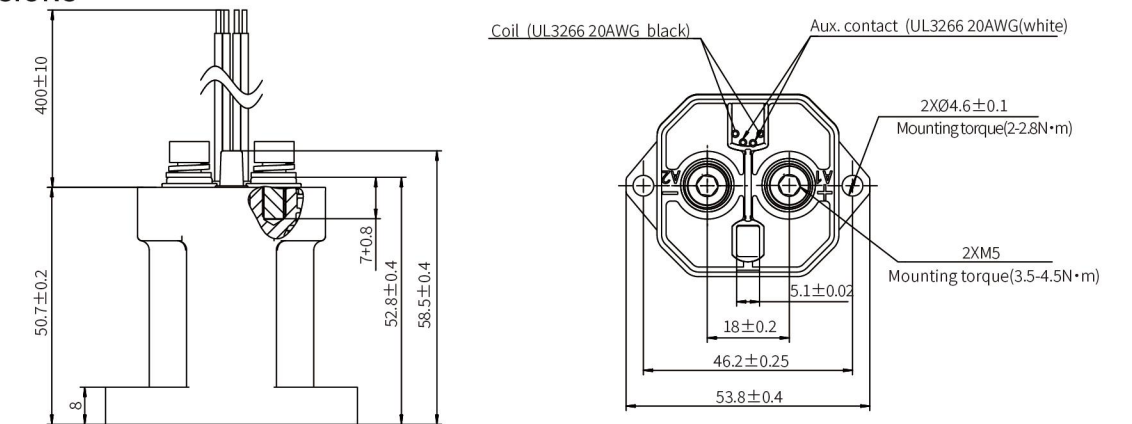

Note: 1.fastener:2xM5x8mm; 2.Mounting hardware M 4, torque 2-2.8N·m; 3.Main contact hardware M 5, torque 3.5-4.5N·m; 4.Main contact to copper area ≥60mm²;

GRAPHS

